

PORT-X direct

180-250 bar | 40-50 l/min

2,610-3,630 psi | 10.6-13.2 gpm

ACCESSORY CARRIER without hydr. circuit

PORTA ACCESSORI senza impianto idr.

GERÄTETRÄGER ohne hydr. Antrieb

PORTEUR D'EQUIPMENTS sans circuit hydr.

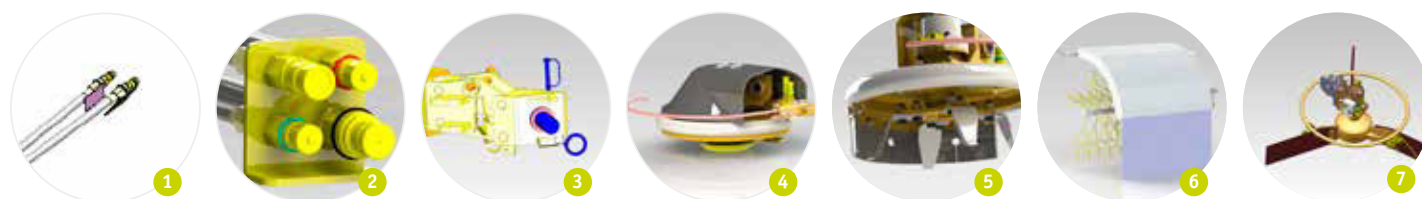
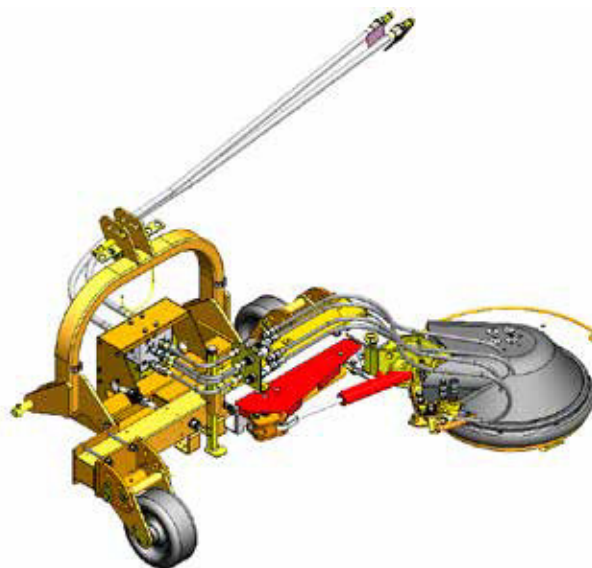

EN

IT

DE

FR

1 Hydraulic connection directly to the tractor	Collegamento idraulico direttamente al trattore	Hydraulischer Anschluß direkt am Traktor	Connexion hydraulique directement sur le tracteur
2 Hydraulic quick coupling	Attacco rapido idraulico	Hydraulische Schnellkupplung	Attelage rapide hydraulique
3 Quick connector for the module	Aggancio rapido per accessori	Schnellverbindung für das Anbaugerät	Attelage rapide pour les accessoires
4 XSC outrigger for inter-row mowing	XSC scansatronchi	XSC Schwenkrad zum Mähen von Gras	XSC roue faucheuse
5 XSA cultivator to eradicate weed	XSA sarchiatore	XSA Zwischenstammkrümmer	XSA roue déracineuse
6 XSP shoot remover	XSP spollonatore	XSP Unterstockbürste	XSP brosse de ceps
7 XAN sweeper	XAN andanatore	XAN Reisigschwader	XAN andaineur

STANDARD VERSION	MODELLO DI BASE	SERIENAUSFÜHRUNG	MODÈLE DE BASE
Accessory carrier PORT-X with quick coupling system X-FAST to connect an accessory module	Porta accessori PORT-X con sistema di attacco rapido X-FAST per il collegamento con un'attrezzo	Geräteträger PORT-X mit Schnellkuppelsystem X-FAST zur Verbindung mit einem Mulchmodulen	Porteur d'équipements PORT-X avec système d'attelage rapide X-FAST pour la connexion d'un module d'accessoire
Hydraulic transmission via tractor	Trasmissione idraulica tramite impianto del trattore	Hydraulischer Antrieb über den Traktor	Transmission hydraulique par le système du tracteur
The PORT-X will be delivered with module/s of choice	Composta da: PORT-X e accessori/o a scelta	Lieferumfang: PORT-X u. Modul/e nach Wahl	Contenu de la livraison: PORT-X et module de choix
Compatible and interchangeable modules: XSC, XSA, XSP, XAN	Accessori compatibili ed intercambiabili: XSC, XSA, XSP, XAN	Kompatible, austauschbare Module: XSC, XSA, XSP, XAN	Modules compatibles et interchangeables : XSC, XSA, XSP, XAN
3-point rear linkage 1 & 2 cat.	Attacco a 3 punti I e II cat.	ISO 3-Punkt-Heckanbau 1. u. 2. Kat.	Attelage à 3 points ISO 1e et 2e cat.
Toucher with spring return mechanism	Tastatore con rientro a molla	Feintaster mit Federrückzug	Palpeur avec retour à ressort
Floating mechanism (for XSC and XSA)	Meccanismo flottante (per XCS e XSA)	Schwebe-Vorrichtung (für XSC und XSA)	Mécanisme flottant (pour XSC et XSA)
Hydraulic telescopic adjustment of working width	Adattamento telescopico idraulico della larghezza di lavoro	Hydraulisch teleskopisches Einstellen der Arbeitsbreite	Réglage télescopique hydr. de la largeur de travail
Support wheels	Ruote di appoggio	Stützräder	Roues d'appui
Electric remote control	Comandi elettrici a distanza	Elektrische Fernbedienung	Commande électrique à distance
Weight* w/o equipment: single 280 kg [620lb], double 340 kg [750lb]	Peso* senza accessori: single 280 kg, double 340 kg	Gewicht* ohne Anbaugeräte: single 280 kg, double 340 kg	Poids* sans accessoire: single 280 kg, double 340 kg

EQUIPMENT ACCESSORI ZUBEHÖR ACCESSOIRES							
cm ["]	cm ["]	cm ["]	cm ["]	cm ["]	cm ["]	cm ["]	cm ["]
XSC 50	50 [20] Ø	125 [49]	160 [63]	240 [94]	-	145 [57]	90 [35]
XSC 60	60 [24] Ø	130 [51]	165 [65]	250 [98]	-	145 [57]	95 [37]
XSC 70	70 [28] Ø	140 [55]	175 [69]	260 [102]	-	150 [59]	95 [37]
XSA	40 [16] Ø	120 [47]	155 [61]	240 [94]	-	135 [53]	80 [31]
XSP	60 [24]	140 [55]	175 [69]	250 [98]	-	140 [55]	90 [35]
XAN	120 [47] Ø	105 [41]	195 [77]	230 [91]	-	160 [63]	110 [43]
2 x XSC 50	-	-	-	-	-	-	-
2 x XSC 60	-	-	-	-	-	-	-
2 x XSC 70	-	-	-	-	-	-	-
2 x XSA	-	-	-	-	-	-	-
2 x XSP	-	-	-	-	-	-	-
2 x XAN	-	-	-	-	-	-	-

PORT-X direct SIDE SHIFT · SPOSTAMENTO LATERALE · SEITENVERSCHIEBUNG · DÉPORT LATÉRAL

A
width-Ø equipment
larghezza-Ø accessorio
Breite-Ø Zubehör
largeur-Ø accessoire

B
width of machine ready for transport
larghezza della macchina pronta al trasporto
Breite des Geräteträgers in Transportstellung
encombrement de la machine en position de transport

D min/max
distance row width
larghezza filare
Reihenabstand
largeur des rangées

L min/max
working width
larghezza di lavoro
Arbeitsbreite
largeur de travail

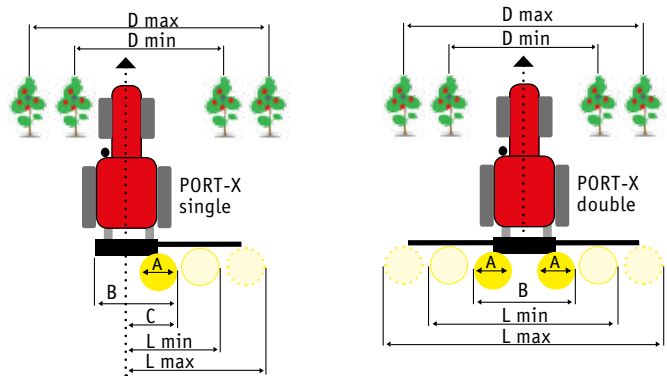

PORT-X direct

REQUIRED HYDR. CONTROL DEVICES · COMANDI IDR. RICHIESTI ·
ERFORDERLICHE STEUERGERÄTE · RACCORDS HYD. REQUIS

	● E-HYD	●
PORT-X direct single	1 (40-50 l/min) 1 (10-15 l/min)	X
PORT-X direct double	X	X

● with electro-hydraulic toucher
con tastatore elettroidraulico
mit elektro-hydraulischem Taster
avec palpeur électro-hydraulique

● without toucher
senza tastatore
ohne Taster
sans palpeur hyd.

	(#470) HYD	
PORT-X direct single	XSC 50	●
	XSC 50	●
	XSC 60	●
	XSC 60	●
	XSC 70	●
	XSC 70	●
	XSA	●
	XSP	●
	XDF	●
XAN	●	
PORT-X direct double	2 x XSC 50	X
	2 x XSC 50	X
	2 x XSC 60	X
	2 x XSC 60	X
	2 x XSC 70	X
	2 x XSC 70	X
	2 x XSA	X
	2 x XSP	X
	2 x XDF	X
	2 x XAN	X

OPTIONS	EN	OPTIONALS	IT	OPTION	DE	OPTIONS	FR	OPT
Hydraulic oil cooler		Scambiatore di calore idr.		Hydr. Wärmetauscher		Échangeur de chaleur hyd.		264
Chevrons		Tabelle di ingombro		Sicherheitsschilder		Panneaux de signalisation		162
Special color		Colore speciale		Sonderfarbe		Couleur spécifique		